

SCXI™-1328 High-Accuracy Isothermal Terminal Block

This guide describes how to install and use the SCXI-1328 high-accuracy isothermal terminal block with the SCXI-1120, SCXI-1120D, and SCXI-1121 modules.

Introduction

The SCXI-1328 high-accuracy isothermal terminal block consists of a shielded board with screw terminals to connect to the SCXI module input connector. The SCXI-1328 has a high-precision thermistor and an aluminum isothermal plate to minimize the temperature gradients across the screw terminals when you measure thermocouples.

The terminal block has 18 screw terminals for easy connection. One pair of screw terminals connects to the SCXI module chassis ground. With the SCXI-1120/D or SCXI-1125, the remaining eight pairs of screw terminals are for signal connection to the eight module inputs. With the SCXI-1121, four pairs of screw terminals are for the four module inputs and four pairs are for the module excitation channels.

What You Need to Get Started

To set up and use your SCXI-1322 terminal block, you need the following items:

- SCXI-1328 terminal block
- SCXI-1328 High-Accuracy Isothermal Terminal Block Installation Guide*
- SCXI chassis
- SCXI-1120, SCXI-1120D, SCXI-1125, or SCXI-1121 module

- Number 1 and 2 Phillips-head screwdrivers
- 1/8 in. flathead screwdriver
- Long-nose pliers
- Wire cutters
- Wire insulation stripper

Conventions

The following conventions are used in this guide:

»

The » symbol leads you through nested menu items and dialog box options to a final action. The sequence **File»Page Setup»Options** directs you to pull down the **File** menu, select the **Page Setup** item, and select **Options** from the last dialog box.



This icon denotes a note, which alerts you to important information.



This icon denotes a caution, which advises you of precautions to take to avoid injury, data loss, or a system crash.

italic

Italic text denotes variables, emphasis, a cross reference, or an introduction to a key concept. This font also denotes text that is a placeholder for a word or value that you must supply.

monospace

Text in this font denotes text or characters that you should enter from the keyboard, sections of code, programming examples, and syntax examples. This font is also used for the proper names of disk drives, paths, directories, programs, subprograms, subroutines, device names, functions, operations, variables, filenames and extensions, and code excerpts.

Safety Information



Cautions *Do not operate the device in an explosive atmosphere or where there may be flammable gases or fumes.*

Keep away from live circuits. Do not remove equipment covers or shields unless you are trained to do so. If signal wires are connected to the device, hazardous voltages may exist even when the equipment is turned off. To avoid a shock hazard, do *not* perform procedures involving cover or shield removal unless you are qualified to do so and disconnect all field power prior to removing covers or shields.

Equipment described in this document must be used in an Installation Category II environment per IEC 664. This category requires local level supply mains-connected installation.

Do not operate damaged equipment. The safety protection features built into this device can become impaired if the device becomes damaged in any way. If the device is damaged, turn the device off and do *not* use until service-trained personnel can check its safety. If necessary, return the device to National Instruments for service and repair to ensure that its safety is not compromised.

Do not operate this equipment in a manner that contradicts the information specified in this document. Misuse of this equipment could result in a shock hazard.

Terminals are for use only with equipment that has no accessible live parts.

Do not substitute parts or modify equipment. Because of the danger of introducing additional hazards, do *not* install unauthorized parts or modify the device. Return the device to National Instruments for service and repair to ensure that its safety features are not compromised.

When using the device with high common-mode voltages, you *must* insulate your signal wires for the highest input voltage. National Instruments is *not* liable for any damages or injuries resulting from inadequate signal wire insulation. Use only 26-14 AWG wire with a voltage rating of 300 V and 60 °C for measuring up to 300 V.

When connecting or disconnecting signal lines to the SCXI terminal block screw terminals, make sure the lines are powered off. Potential differences between the lines and the SCXI ground create a shock hazard while you connect the lines.

Connections, including power signals to ground and vice versa, that exceed any of the maximum signal ratings on the SCXI device can create a shock or fire hazard or can damage any or all of the boards connected to the SCXI chassis, the host computer, and the SCXI device. National Instruments is *not liable for any damages or injuries* resulting from incorrect signal connections.

If high voltages ($\geq 30 V_{\text{rms}}$ and $42.4 V_{\text{peak}}$ or 60 VDC) are present, *you must connect a safety earth ground wire to the terminal block safety ground solder lug*, shown in Figure 1. This complies with safety agency requirements and protects against electric shock when the terminal block is not connected to the chassis. To connect the safety earth ground to the safety ground solder lug, run an earth ground wire in the cable from the signal source to the terminal block. National Instruments is *not liable for any damages or injuries* resulting from inadequate safety earth ground connections.

Do *not* loosen or re-orient the safety ground solder lug hardware when connecting the safety ground wire; to do so reduces the safety isolation between the high voltage and safety ground.

Clean devices and terminal blocks by brushing off light dust with a soft, nonmetallic brush. Remove other contaminants with deionized water and a stiff nonmetallic brush. The unit must be completely dry and free from contaminants before returning to service.

Temperature Sensor Output and Accuracy

The SCXI-1328 temperature sensor outputs 1.91 to 0.58 V from 0 to 55 °C and has an accuracy of ± 0.5 °C over the 15 to 35 °C range and ± 0.9 °C over the 0 to 15 °C and 35 to 55 °C ranges ¹.

National Instruments software can convert a thermistor voltage to the thermistor temperature for the circuit diagram shown later in this guide. In LabVIEW, you can use the Convert Thermistor Reading VI in the **Data Acquisition»Signal Conditioning** palette. If you are using LabWindows/CVI or NI-DAQ, use the `Thermistor_Convert` function. The VI takes the output voltage of the temperature sensor, the reference voltage, and the precision resistance and returns the thermistor temperature.

Alternatively, you can use the following formulas:

$$T(^{\circ}\text{C}) = T_K - 273.15$$

where T_K is the temperature in kelvin

$$T_K = \frac{1}{[a + b(\ln R_T) + c(\ln R_T)^3]}$$

$$a = 1.295361 \times 10^{-3}$$

$$b = 2.343159 \times 10^{-4}$$

$$c = 1.018703 \times 10^{-7}$$

R_T = resistance of the thermistor in ohms

$$R_T = 5,000 \left(\frac{V_{TEMPOUT}}{2.5 - V_{TEMPOUT}} \right)$$

$V_{TEMPOUT}$ = output voltage of the temperature sensor

$$T(^{\circ}\text{F}) = \frac{[T(^{\circ}\text{C})]9}{5} + 32$$

where $T(^{\circ}\text{F})$ and $T(^{\circ}\text{C})$ are the temperature readings in degrees Fahrenheit and degrees Celsius, respectively.



Note Use an average of a large number of samples to obtain the most accurate reading. Noisy environments require more samples for greater accuracy.

¹ Includes the combined effects of the temperature sensor accuracy and the temperature difference between the temperature sensor and any screw terminal. The temperature sensor accuracy includes tolerances in all component values, the effects caused by temperature and loading, and self-heating.

Signal Connection



Note Refer to the [Safety Information](#) section before removing equipment covers or connecting or disconnecting any signal wires.

When connecting your signals to the SCXI-1328, follow the labeling on the SCXI-1328 for the appropriate module, as indicated in Figure 2.

To connect the signal to the terminal block, perform the following steps, referring to Figures 1 and 2 as necessary:

1. Unscrew the top cover screws and remove the cover.
2. Loosen the strain-relief screws and remove the strain-relief bar.
3. Run the signal wires through the strain-relief opening. You can add insulation or padding if necessary.
4. Prepare your signal wire by stripping the insulation no more than 12 mm.
5. Connect the wires to the screw terminals by wrapping the wires around the screw. No bare wire should extend past the screw head. Exposed wire reduces the safety isolation between the high voltage and safe low voltages.
6. Tighten the screws to a torque of 5–7 in.-lb.
7. Connect safety earth ground to the safety-ground solder lug. Refer to the [Safety Information](#) section for connection information.
8. Reinstall the strain-relief bar and tighten the strain-relief screws.
9. Reinstall the top cover and tighten the top cover screws.
10. Connect the terminal block to the module front connector as explained in the [Installation](#) section.

Figure 1 shows the SCXI-1328 terminal block parts locator diagram.

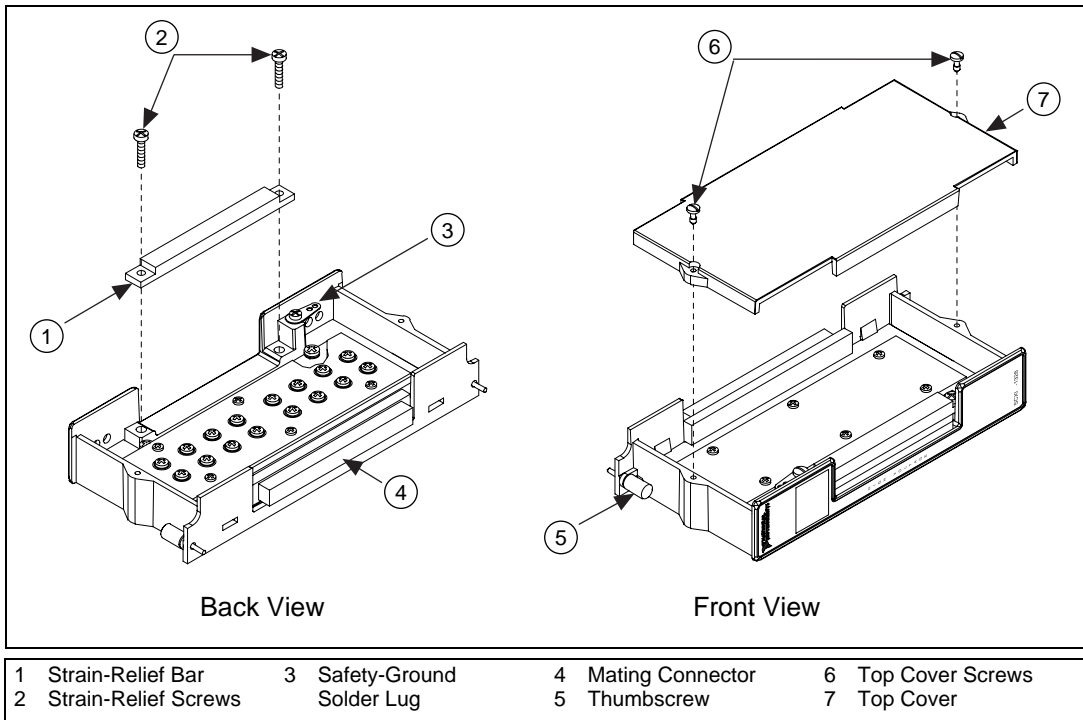

Figure 1. SCXI-1328 Parts Locator Diagram

Figure 2 shows the SCXI-1328 signal connections.

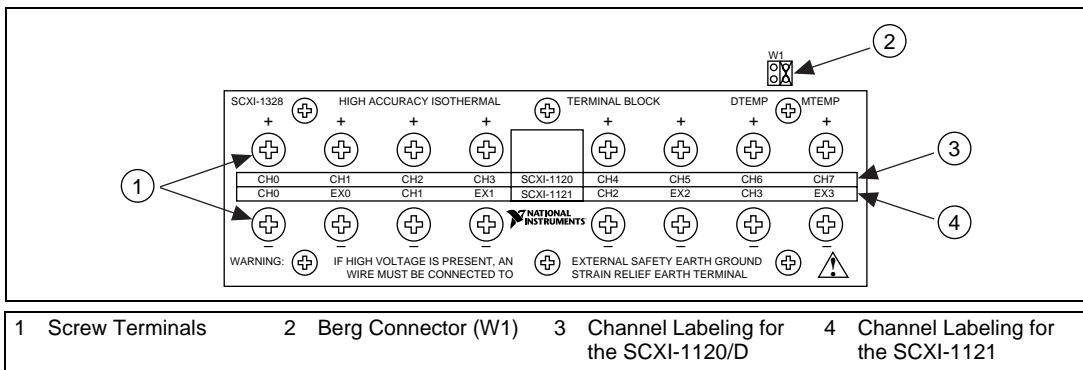

Figure 2. SCXI-1328 Signal Connections

Installation

To connect the terminal block to the SCXI module front connector, perform the following steps:

1. Connect the module front connector to its mating connector on the terminal block.
2. Tighten the top and bottom thumbscrews on the back of the terminal block to hold it securely in place.



Note For accurate cold-junction compensation, place the SCXI chassis away from an extreme temperature differential.

Specifications

Cold-junction sensor

Accuracy ¹	0.5° from 15 to 35 °C 0.9° from 0° to 15 °C and 35 to 55 °C
Repeatability	0.2° from 15 to 35 °C
Output	1.91 to 0.58 V from 0 to 55 °C

Common-mode isolation

Channel to channel.....	300 V _{rms}
Channel to ground.....	300 V _{rms}

Environment

Operating temperature.....	0 to 50 °C
Storage temperature	-20 to 70 °C
Relative humidity	5% to 90% noncondensing

Safety

Designed in accordance with IEC 61010-1, UL 3111-1, and CAN/CSA C22.2 No. 1010.1 for electrical measuring and test equipment.
Approved at altitudes up to 2000 meters.
Installation Category II
Pollution Degree 2

¹ Includes the combined effects of the temperature sensor accuracy and the temperature difference between the temperature sensor and any screw terminal. The temperature sensor accuracy includes tolerances in all component values, the effects caused by temperature and loading, and self-heating.

Temperature Sensor Circuit Diagram

You do *not* need to read this section to operate the SCXI-1328. The circuit diagram in Figure 3 is optional information you can use if you want more details about the SCXI-1328 temperature sensor.

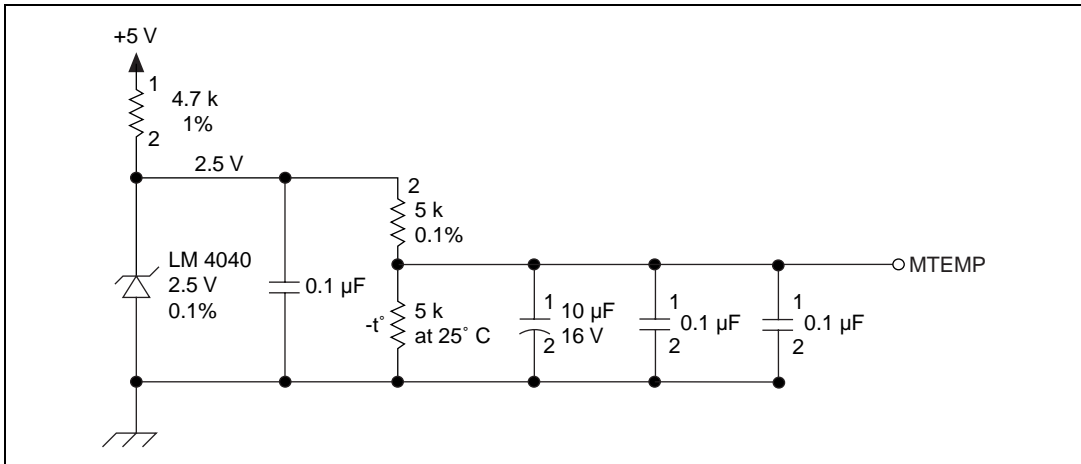

Figure 3. Temperature Sensor Circuit Diagram

Technical Support Resources

NI Web Support

To provide you with immediate answers and solutions 24 hours a day, 365 days a year, National Instruments maintains extensive online technical support resources. They are available to you at no cost, are updated daily, and can be found in the Technical Support section of our Web site at www.ni.com/support

Worldwide Support

National Instruments has offices located around the globe. Many branch offices maintain a Web site to provide information on local services. You can access these Web sites from www.ni.com/worldwide

For telephone support in the United States, dial 512 795 8248. For telephone support outside the United States, contact your local branch office:

Australia 03 9879 5166, Austria 0662 45 79 90 0, Belgium 02 757 00 20, Brazil 011 284 5011, Canada (Calgary) 403 274 9391, Canada (Ontario) 905 785 0085, Canada (Québec) 514 694 8521,

China 0755 3904939, Denmark 45 76 26 00, Finland 09 725 725 11,
France 01 48 14 24 24, Germany 089 741 31 30, Greece 30 1 42 96 427,
Hong Kong 2645 3186, India 91805275406, Israel 03 6120092,
Italy 02 413091, Japan 03 5472 2970, Korea 02 596 7456,
Mexico (D.F.) 5 280 7625, Mexico (Monterrey) 8 357 7695,
Netherlands 0348 433466, Norway 32 27 73 00, Poland 48 22 528 94 06,
Portugal 351 1 726 9011, Singapore 2265886, Spain 91 640 0085,
Sweden 08 587 895 00, Switzerland 056 200 51 51,
Taiwan 02 2377 1200, United Kingdom 01635 523545



321877B-01

Nov99